

# KUREK KULOWY

## WYKONANIE WG WYMAGAŃ SPECJALNYCH

Gwinty przyłączeniowe rurowe stożkowe wewnętrzne „NPT” wg ANSI B2.1.

Nr kat.

# ZC-1

WYKONANIE SPECJALNE (4)

DN10(¼); 10; 15; 20; 25;  
- PN16; 25; 40; 63; 100

DN32; 40 - PN16;25;40;63

DN50 - PN16;25;40

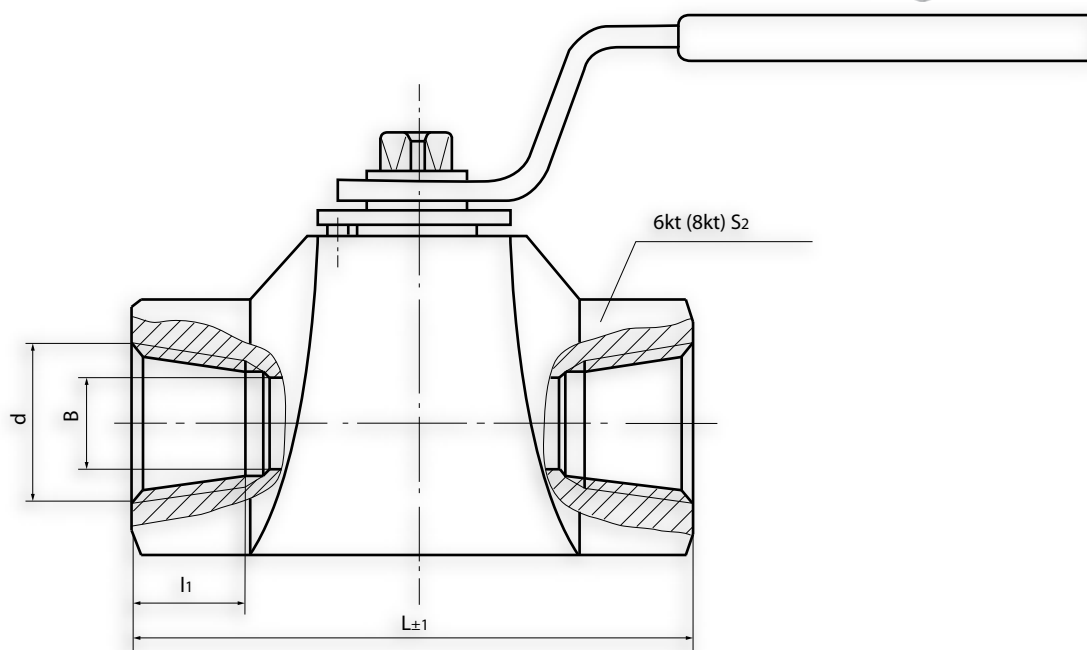

DN	d	B	l <sub>1</sub>	L	S <sub>2</sub>	MASA
						~kg
mm						
10	¼-18NPT	10	11,6	77	32	
10	⅜-18NPT	10	12,6	77	32	
15	½-14NPT	15	16,2	83	32	
20	¾-14NPT	20	17,7	96	41	
25	1-11½NPT	25	20,8	113	52	
32	1¼-11½NPT	32	21,4	116	52	
40	1½-11½NPT	39	21,8	130	60	
50	2-11½NPT	49	22,3	145	75	
50	2½-8NPT	49	32,5	174,2	85	