

KUREK KULOWY

WYKONANIE WG WYMAGAŃ SPECJALNYCH

Gwinty przyłączeniowe rurowe walcowe zewnętrzne „G” wg PN-EN ISO 228-1:2005.

Nr kat.

ZC-1

WYKONANIE SPECJALNE (2)

DN10(1/4); 10; 15; 20; 25; 32
PN16; 25; 40; (63; 100)¹⁾
(DN40; 50)¹⁾

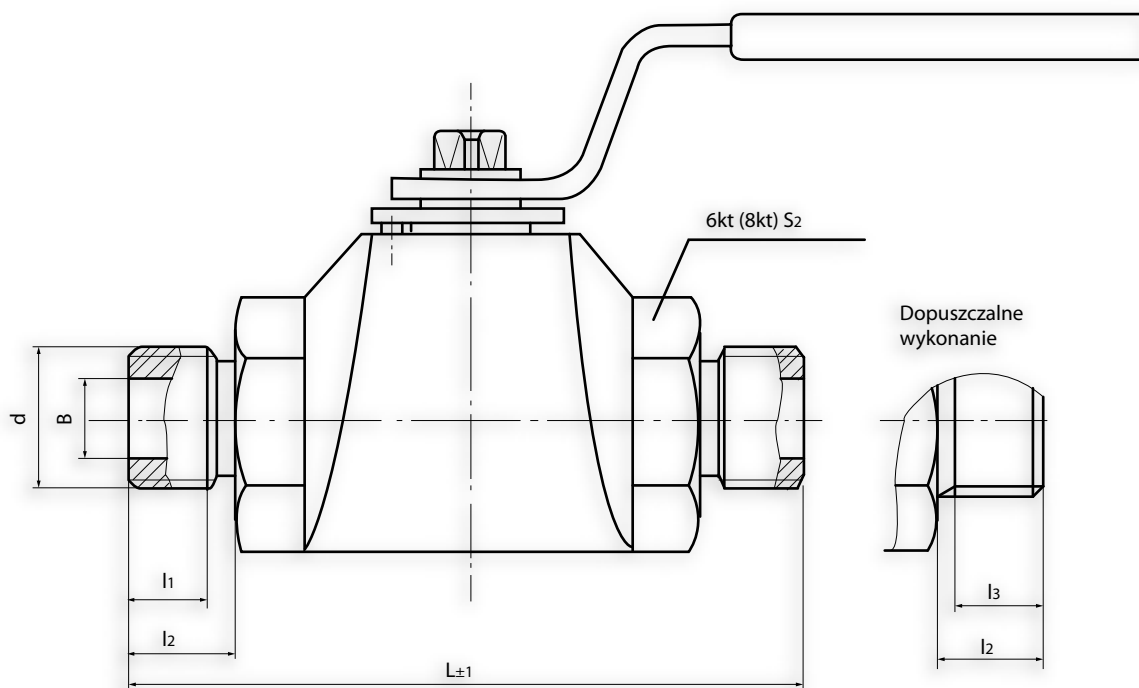

DN	d	B	l ₁	l ₂	l ₃	L	S ₂	MASA
								~kg
mm								
10	G ¹ / ₄	7,4	8,5	11	9	85	32	
10	G ³ / ₈	10	8,5	11,5	9,5	90	32	
15	G ¹ / ₂	12	12	15	13	97	32	
20	G ³ / ₄	17,5	14	18	15,5	114	41	
25	G ₁	22,5	16	20	17,5	133	52	
32	G ¹ / ₂	29	16,5	21,5	19	146,8	52	

¹⁾ Wykonane wg wymagań specjalnych - po uzgodnieniu